

Black Teknigas

Powerseat® Eco Gas Safety Shut-Off Valve

Technical, Installation and Maintenance Details



Features

- Safety shut off valves for gas, air and oil
- EN161 approved; EC certificated
- Certified to IP56 for Powerseat Eco Range
- Electro-hydraulic slow opening operation
- Closure in less than 1 second
- Open & closed position switch (*volt free*) as standard
- With the new Powerseat® Eco range, all valves now feature integral manual reset switch as standard
- Red LED. 'Power on' indicator (*if reset function is used*)
- Green LED. 'Valve open' indicator
- Ultra high flow rate/connection size ratio
- Removable strainer for easy maintenance
- Suitable for vertical or horizontal mounting
- Plugged test points both sides of body
- Remote emergency stop switches available
- Remote thermal fuses available
- 20mm entry for cable or conduit entry
- Available in 110V and 230V 50/60Hz versions
- Energy saving feature (*PE6683-PE6689 only*)
- Flanged and screwed body connections
- Amber flashing LED. 'Valve opening' indicator (*BC66810 & BC66811 model only*)
- Membrane type control panel on actuator (*BC66810 & BC66811 model only*)

Description

The Powerseat® family is an electro-hydraulically operated range of gas safety shut-off valves with ultra-high flow rates and a range of associated accessories. Their primary function is the on-off control of low pressure combustible gases, air and oil and may be used for both control and safety shut-off purposes. The valves are suitable for the three families of combustible gas as follows, 1st, Town Gas; 2nd, Natural Gas and 3rd, Liquefied Petroleum Gases. They are suitable for oil with a viscosity of up to 200 seconds Redwood.

The valves are normally closed, i.e. Energise to open, and are operated from a.c. mains at 230 or 110 volts. Electro-hydraulic operation ensures a smooth, controlled opening at low speed whilst closure time is less than 1 sec.

Powerseat® is available in connection sizes from 1½" (DN40) to 3" (DN80) screwed, and from DN65 (2½") to DN250 (10") Flanged, thereby covering an extremely wide range of commercial and industrial applications. Complementary high quality solenoid valves are available to cover smaller sizes, where the ultra-high flow rate of the Powerseat® is not so important.

Valve construction consists of either a die cast aluminium screwed body, or cast Iron flanged body, a removable stainless steel strainer and an actuator having the valve closure head as an integral part. The actuator may be removed from the body for servicing and access to the strainer without removal of the body from the line.

The actuator consists of a pump and motor, a relief valve, operating cylinder, piston and push rod, valve head and seals, hydraulic fluid and electrical switchgear. When the valve is energised the relief valve closes, the motor starts and the pump forces fluid into the cylinder driving the valve open. At this point the closed position switch contacts change

state (this does not affect the operation of the valve as they would typically be connected to an external burner sequence control). When the fully open position is reached a limit switch changes state, switches off the pump motor and illuminates a Green LED indicator on the case to show that the valve is fully open. An open position switch will also change state, again without affecting the valve operation as it will be connected to an external control system.

The relief valve remains closed and will do so until power is removed. Removal of power causes the relief valve to open and the safety shut off valve to close.

With the introduction of the new Powerseat® Eco range, all valves now feature an integral manual reset switch as standard which can be wired out at any time. Additional remote manual rest switches are available as accessories for on-site fitting. When wired in, both options require manual intervention to operate the valve after mains interruption, i.e. after a power cut or when the valve is first energised. To facilitate this, the 'reset button' is momentarily depressed latching the reset switch in the 'on' position allowing the valve to operate.

Unique features of the 200mm and 250mm Powerseat® (BC66810 & BC66811)

These valves feature a membrane covered control panel on the actuator. Upon energising the valve a Red LED illuminates on the control panel and remains illuminated whilst power is 'on' to the valve.

Whilst the pump is running an Amber LED on the control panel flashes to indicate that the valve is opening. This goes out when the valve is fully open and is replaced with a green 'open' LED.

Flow Charts

PE6683 TO PE6687 MODELS

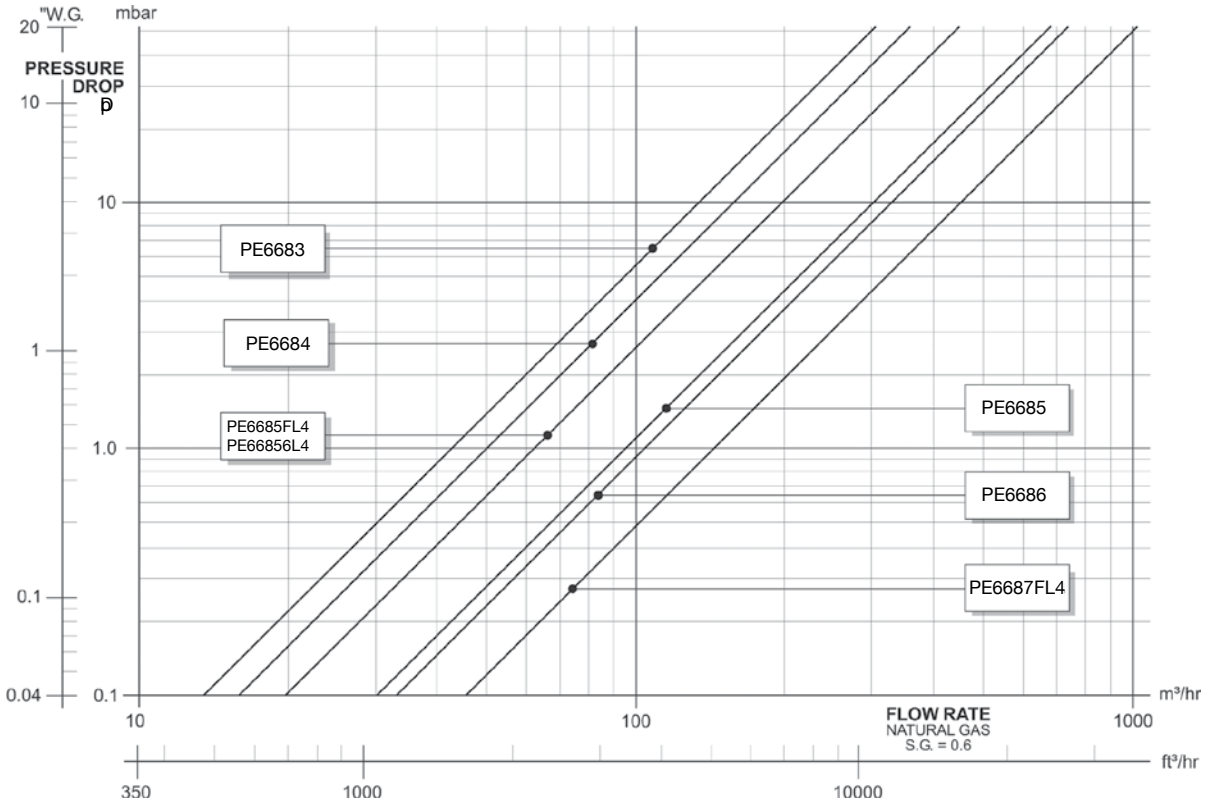

PE6689, BC66810, BC66811 MODELS

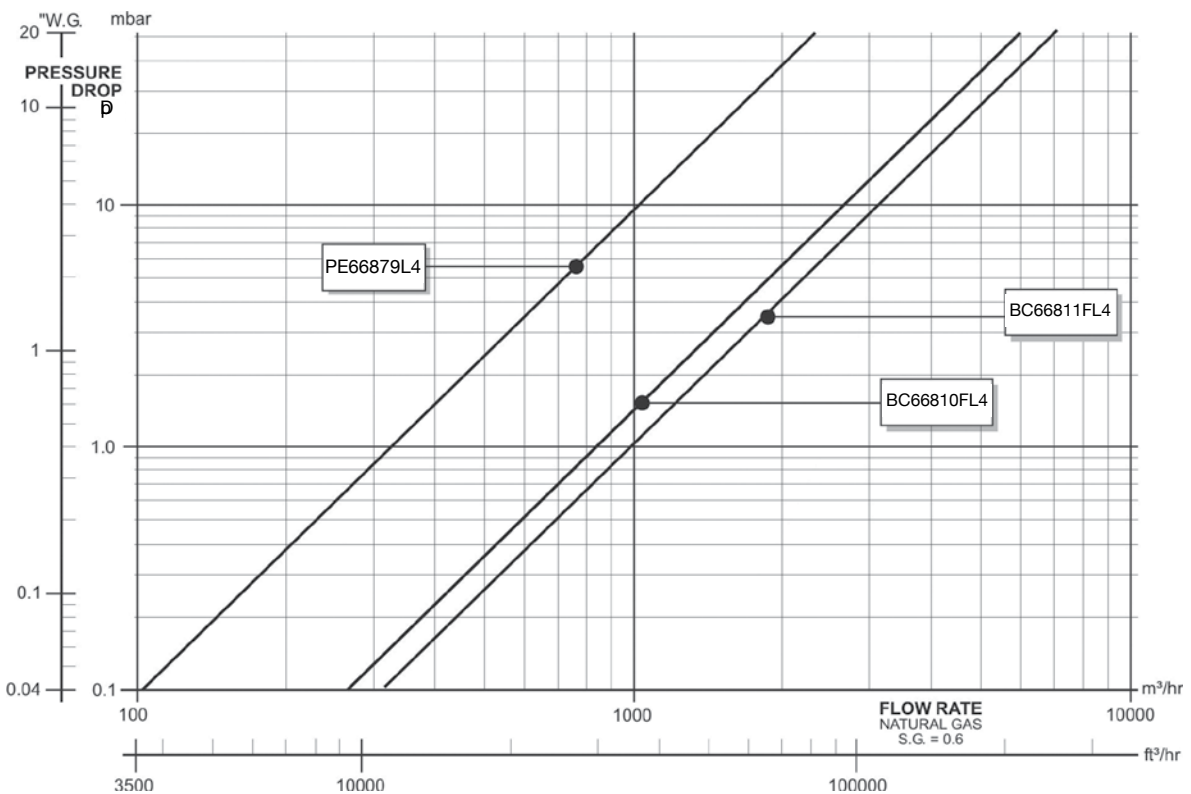

Dimensions

PE6683, PE6684

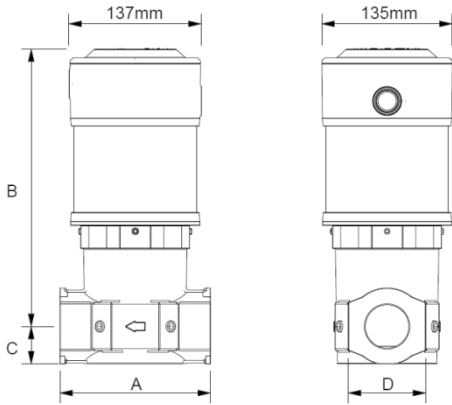

PE6685, PE6686

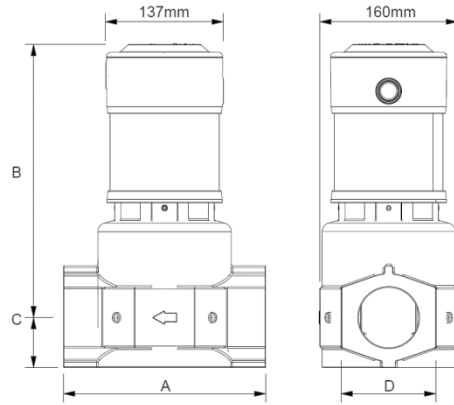

PE6685FL4, PE6686FL4, PE6687FL4

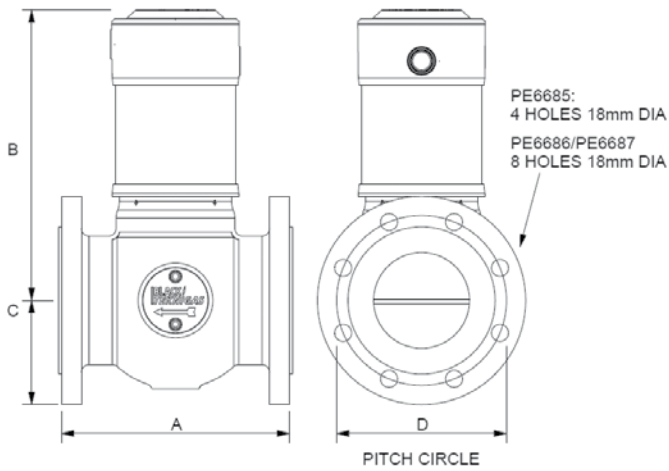

PE6689FL4

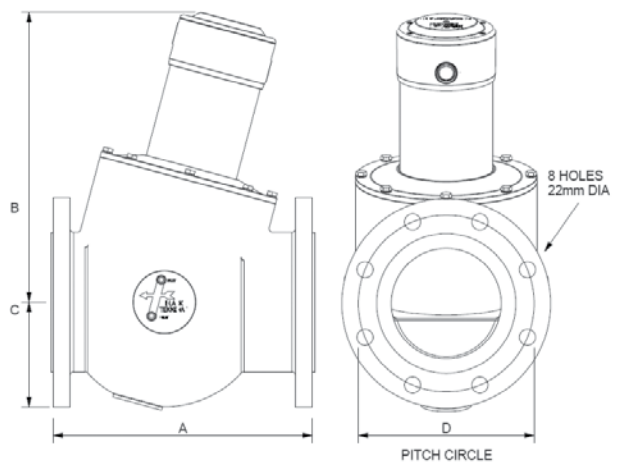

BC66810FL4, BC66811FL4

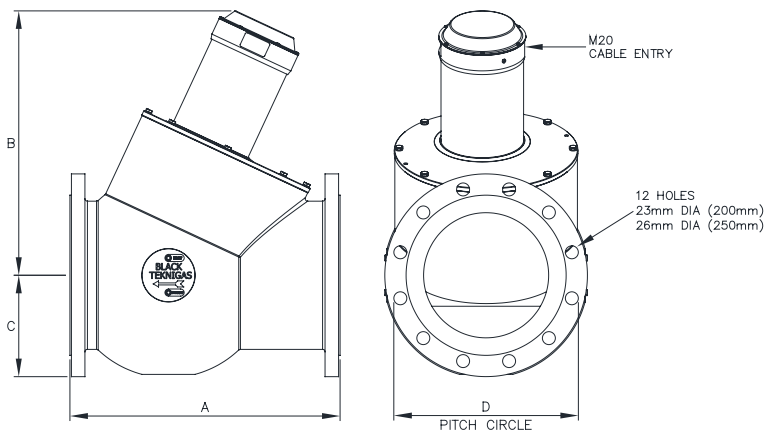

SPARE ACTUATOR INSTALLATION/REMOVAL

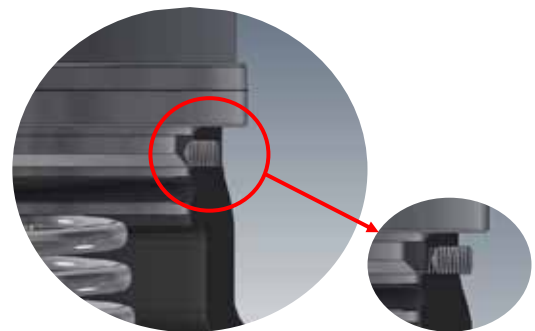

Energise valve. Ensure 4x screws on valve body (6683-6687 model) are loosen enough for clearance before removing/installing Actuator.

Specification

Media:

Non-corrosive gases, air, oil
(up to 200 sec. Redwood No.1)

Combustible gases, families
1 (town gas), 2 (natural gas) and 3 (L.P.G.)

Media Temperature Range:

-15°C to +60°C

Ambient Temperature Range:

-15°C to +60°C

Opening Speed:

PE6683 - PE6687: 10 seconds max.
PE6689: 30 seconds max.
BC66810 & BC66811: 70 seconds max.

Closing Speed: < 1 second

Electrical:

Versions available: 110V or 230V 50/60Hz
220V 60Hz

Model PE6683-PE6689 has push in terminal
and BE66810 and BE66811 has screw terminals.
All models have provision for earthing

Rating:

PE6683 - PE6689
Opening: 200VA
Fully Open (all versions): 10VA

BC66810 - BC66811
Opening: 220VA
Fully Open: 37VA
Closed and Open
Position Switch Ratings: Volt free contacts

250V a.c. or 30V d.c: 5A max. resistive
2A max. inductive

Manual Reset Switch:

Time to drop out after
removal of power: Typically 10ms

Mounting:

Vertical or Horizontal, actuator
in upper hemisphere: See installation section

Connections:

Flanged or screwed: See table below

Flanged connections to BSEN1092;
PN16 flanges (ISO7005)

Screwed connections to BSEN10226
Rp designated (ISO7-1) threads

Pressure Test Points:

Upstream and downstream of seat,
both sides of body, plugged Rc 1/4

Strainer:

All models: removable stainless steel mesh

Approvals:

All models approved to EN161,
Class A Group 2 construction

EC certificated

Maximum Operating Pressure:

Maximum forward and reverse
operating pressures - see table below

Flow:

See table below and chart on page 3

Dimensions and Weight:

See table below

Valve Type	Connection	Actuator	Orifice Diameter mm	Maximum Flow Natural Gas S.G.0.6		Maximum Operating Pressure		Net Weight Kg	Dimensions, mm Refer to diagram			
				p2.5mbar m ³ /hr	p1"W.G. ft ³ /hr	Forward m bar	Reverse m bar		A	B	C	D
Powerseat® Eco Specification												
PE6683	1.5" Screwed	PE668S	50	67	2345	1000	150	5	156	289	39	79
PE6684	2" Screwed	PE668S	50	80	2800	1000	150	5	156	289	39	79
PE6685	2.5" Screwed	PE668LS	76	150	5250	350	150	7	235	317	58	110
PE6686	3" Screwed	PE668LS	76	165	5775	350	150	7	235	317	58	110
PE6685FL4	65mm Flanged	PE668HS	76	100	3500	350	150	22	219	268	93	145
PE6686FL4	80mm Flanged	PE668HS	76	100	3500	350	150	23	219	268	102	160
PE6687FL4	100mm Flanged	PE6687S	96	220	7700	250	150	30	248	308	110	180
PE6689FL4	150mm Flanged	PE6689S	150	510	17850	500	150	60	360	395	143	240
Powerseat® Original Specification												
BC66810FL4	200mm Flanged	BC66810S	200	1200	42000	250	150	102	458	485	170	295
BC66811FL4	250mm Flanged	BC66811S	250	1430	50050	250	150	160	540	530	203	355

Maintenance

There are no user serviceable parts in the actuator except the valve rubber, which may be cleaned with turpentine substitute. To remove actuator, isolate valve from gas supply and proceed as follows.

All Models Except BC66810 and BC66811

Energise to open valve, unscrew the 4 screws around periphery of body neck, ensure the screws are loosen enough for clearance to avoid damaging the 'O' ring before withdrawing the actuator. See illustration on page 4 - PE6683-PE6687 models only. (On model PE6689 unscrew 8 bolts around actuator flange) On no account must the socket screws in the actuator base plate be touched. De-energise. The strainer may be removed, cleaned and refitted. If fitting replacement actuator, isolate electrical supply and re- connect to new actuator. Ensure there are screws clearance to avoid damaging the 'O' ring. Energise, refit actuator to body and tighten the 4 screws around body neck (8 bolts in flange - PE6689) to retain. De-energise and leak test.

BC66810 and BC66811 Models

Remove switch housing cover. Using the 1.5mm Hex key supplied, loosen both screws in the brass CPI collar around the actuating rod. Replace cover. Energise to open valve, unscrew the 8 hexagon bolts around actuator flange. Insert 2 x M6 bolts (not supplied) into threaded holes located on upper outside edge of flange. Use bolts to lever actuator off. De-energise. The strainer may be removed, cleaned and

refitted. If fitting replacement actuator, isolate electrical supply and re-connect to new actuator. Energise, refit to body and tighten the 8 bolts around the actuator flange to retain. De-energise and remove switch housing cover. Adjust CPI collar to just above closed position (approx. 1mm) tighten its screws and replace the switch housing cover. Test for leaks.

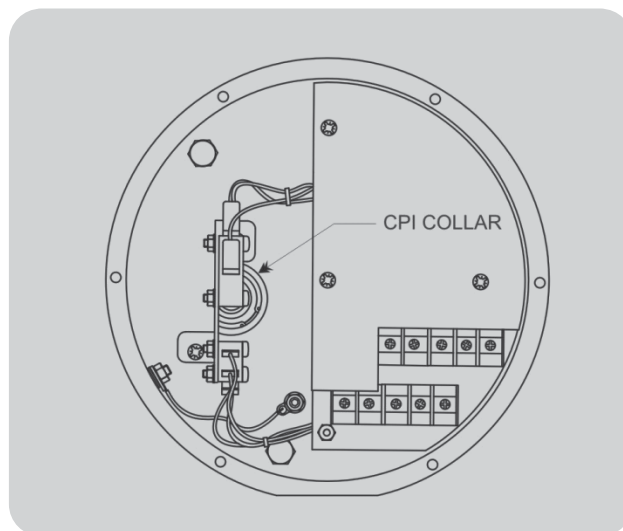

Note: The eight screws around actuator flange on models PE6689, BC66810 and BC66811 should be tightened to a torque of 20Nm (14.75 lb ft) to retain.

Troubleshooting

Condition	Possible causes	Action
No Power	Incorrect electrical connection, wrong voltage	Check power connection, ensure correct voltage
Valve not opening with red indicator	Manual reset is on after power interruption (Power cut)	Push reset button on actuator
Oil leakage	Actuator orientation, loose screws, damage to actuator components	Check actuator, contact supplier if there is excessive or consistent loss
Motor starting & stopping at interval	Fault with internal hydraulic system	Switch off actuator for 1 hour & restart. If problem persists contact supplier.
Motor running continuously	Fault with internal hydraulic system, electronic fault	Switch off actuator for 2 hours to cool down & restart. If problem persists contact supplier.
Losing pressure	Flange or test point sealing, damaged 'O' ring (on Powerseat Eco 6683-6687 models only)	Re-sealing, replace 'O' ring (Spare supplied for Powerseat Eco 6683-6687 models only). If problem persists contact supplier.

Accessories

Manual Reset Switch

Features

A push button operated switch which isolates the electrical supply to the valve in the event of power failure.

When power is subsequently restored to the valve, the push button must be depressed before the valve will open after which operation is as normal.

The Manual Reset Switch is remote mounted.

Specification

Product Code:	BC66RSR230V
Consumption:	1VA max.
Drop out time:	Typically 10ms
Protection:	IP65

Emergency Cut Out Switch

Features

A remote mounted push-to-break contacts/twist-to-reset contacts switch for emergency use. Available in metal or plastic (with optional key switch) wall mounting box.

Specification

Product Code:	BC66ESB (Metal box) BC66ESB/P (Plastic box) BC66ESB/K (Key switch)
Contacts:	10A 500V max. Single pole (Extra contact blocks may be retro fitted)
Cable entry:	20mm
Temp. range:	-25°C to +70°C
Protection:	BC66ESB – IP65 Others – IP40



Provengas Automatic Gas Proving System

Features

An automatic proving system for gas installations comprising a control panel and an isolating unit. Connects into gas supply to safety shut off valve and proving cycle is manually initiated from control panel. Has integral time switch for timed shut down and features key switch and emergency cut out switch for safety and security. Easy installation and commissioning, for use with any solenoid or electrohydraulic gas safety shut off valves.

Specification

Product Code:	PG001
Compatibility:	1st, 2nd & 3rd Family Gases
Electrical Supply:	230V 50Hz, 2A fused Gas Supply: 20mbar to 60mbar Ambient and Media Temp: 0°C to 55°C

Thermal Fuse

Manually Resettable Version

Features

A remote mounted thermally operated manually resettable fuse in a vented metal housing. Mounting orientation universal. Wired in series with the valve, the fuse will open circuit at a predetermined temperature, interrupting the supply to the valve, which will then close. A knob on the front of the unit is rotated through ¼ turn to reset the unit.

Specification

Product code:	BC66MRF
Electrical rating:	Single pole changeover 5A max. 230V a.c. (resistive and inductive)
Fusing temperature:	Nom. 70°C; 10°C reset differential

Non Resettable Version

Features

A remote mounted thermally operated non-resetting fuse in a vented metal housing suitable for wall mounting. Wired in series with the valve, the fuse will open circuit at a predetermined temperature, interrupting the supply to the valve, which will then close.

Specification

Product code:	BC66ETF
Electrical rating:	15A max. 230V a.c.
Fusing temperature:	72°C standard

