

Series HKFC20

Pump mixing groups with electronic fix-point control for heating systems

EN Installation and operating manual
(translated from the original operating manual)



Contents

1	General Information	2
1.1	Important information about the installation and operating manual.....	2
1.2	Notes on supplier documents.....	2
1.3	Product conformity.....	2
1.4	Product Features.....	2
1.5	Product Labeling	2
2	Safety	3
2.1	Safety notices.....	3
2.2	Important safety instructions.....	3
2.3	Intended use	3
2.4	Foreseeable misuse.....	3
2.5	Responsibilities of the operator.....	3
2.6	Groups of persons.....	3
3	Technical specification	4
4	Pressure loss diagram	5
5	Dimensions	5
6	Component overview	6
7	Installation and commissioning	6
7.1	General safety information	6
7.2	Installation diagram.....	7
7.3	Installation	7
7.4	Starting the unit	7
7.5	Controller and actuator adjustment.....	7
7.6	Thermometer settings.....	7
7.7	Switching the supply and return lines.....	8
8	Maintenance	9
8.1	General safety information	9
8.2	Annual maintenance schedule	9
8.3	Replacing wear parts.....	9
8.4	Removing the circulation pump	9
8.5	Installing the circulation pump.....	9
8.6	Fitting the 3-way mixing valve	10
8.7	Fitting the actuator	10
9	Disposal	11
9.1	Notification of administrative bodies and the manufacturer	11
9.2	Return to the manufacturer.....	11
10	Warranty	11

1 General Information

1.1 Important information about the installation and operating manual

NOTICE

The plant operator is responsible for ensuring compliance with the local laws and regulations (e.g. accident prevention regulations, etc.).

Incorrect operation or operating the product (Pump group HKFC20) outside the specifications invalidates all warranty claims. This Installation and Operating Manual

- is the component of the product (HKFC20);
- contains instructions and information on safe and correct installation and commissioning of the product (HKFC20);
- must be available to all users throughout the entire service life of the product (HKFC20);
- is intended for trained personnel who are familiar with the applicable standards and provisions and, in particular, with the relevant safety concepts and the operation and maintenance of the product (HKFC20);
- is protected by copyright and may not be changed without the manufacturer's permission.

1.2 Notes on supplier documents

The supplier documents contain specific information on the components, their technical features, installation instructions and other relevant details. Read these documents carefully and retain with this manual. The supplier documents cover the following:

- Circulation pump operating instructions
- Actuator operating instructions

1.3 Product conformity

For the product (Pump group HKFC20), conformity according to Machinery Directive 2006/42/EC is declared.

1.4 Product Features

- Patented 3-part EPP insulation shell.
- All connections to the system the external thread G 1 flat sealing.
- Stable wall mount incl. mounting hardware.
- Compact, space-saving design.

1.5 Product Labeling

The data plate is located on the inside of the insulation front shell.

2 Safety

2.1 Safety notices

DANGER

DANGER indicates an imminent danger that may cause serious physical injury or death if the appropriate safety precautions are not in place.

WARNING

WARNING indicates a danger arising through incorrect behaviour (e.g. misuse, disregarding notices, etc.) that may cause serious physical injury or death.

CAUTION

CAUTION indicates a potentially dangerous situation that may cause minor or slight injuries if the appropriate safety precautions are not in place.

NOTICE

NOTICE indicates a situation that may cause material damage if the corresponding precautions are not taken.

2.2 Important safety instructions

- Before using, carefully read through this operating manual.
- Only trained specialist personnel are permitted to perform maintenance, cleaning and repair work.
- The product (HKFC20) must not be used if it is damaged or is no longer operating correctly. In this case, contact your specialist dealer immediately.
- Adhere to the maintenance instructions and intervals.
- Protect the product (HKFC20) from the influences of weather.
- Never use the product (HKFC20) outdoor.
- The product (HKFC20) is only permitted to be used for the purpose for which it was intended.

2.3 Intended use

Pump groups (HKFC20) for distributing heating water in heating systems.

The product (Pump group HKFC20) is not intended to be operated by people (including children) with physical, sensory or mental disabilities, nor by people with insufficient experience or previous knowledge.

2.4 Foreseeable misuse

The following is considered to be foreseeable misuse:

- Operating the product (HKFC20) contrary to the specifications.
- Improper use of the product (HKFC20).
- Modifications to the product (HKFC20) that were not agreed with the manufacturer.
- Using replacement or wear parts not approved by the manufacturer.
- Operating the product (HKFC20) outdoors (parts and components are not UV resistant).

2.5 Responsibilities of the operator

The operator must ensure that:

- The product (HKFC20) is only used for its intended purpose.
- The product (HKFC20) is installed, operated and maintained according to the specifications in the Installation and Operating Manual.
- The product (HKFC20) is only operated according to local regulations and occupational health and safety regulations.
- All precautionary measures have been carried out to avoid dangers originating from the product (HKFC20).
- All precautionary measures for first aid treatment and firefighting have been carried out.
- Only authorized and trained users have access to the product (HKFC20) and operate it.
- Users have access to this Installation and Operating Manual at all times.

2.6 Groups of persons

Only qualified persons may operate the product (Pump group HKFC20) or perform service and maintenance work.

User

A user is deemed to be qualified if they have read these operating instructions and understood the potential risks associated with incorrect behavior.

Fitter/commissioner

Due to their specialist training and knowledge, and taking into consideration the applicable standards, provisions, regulations and laws, a fitter/commissioner is capable of performing work on the product (HKFC20) and recognizing and avoiding potential risks.

System planner

The system planner is responsible for evaluating these parameters and developing workarounds.

3 Technical specification

Hydraulic data	
Max. operating pressure	6 bar
Ambient temperature	-2 to +40 ° (see pump specifications)
Operating temperature	+2 to +90 ° (see pump specifications)
Gravity brake opening pressure	10 mbar
Kvs mixing valve	6.3 m³/h
Temperature display range	0 - 120 °C
Temperature setting range	0 - 80 °C
Nominal width	DN 20
Media	Water or water with glycol as per VDI (Association of German Engineers) 2035 / ÖNORM (Austrian standard) 5195
Electrical connection	
Power supply	See separate pump documentation
Dimensions	
Width x height x depth with EPP shell	240 x 310 x 217 mm
Centre distance	90 mm
Sealing surfaces distance	293 mm
Weight	
Weight without packaging	2.9 kg without pump; 4.7 - 4.8 kg with pump, depending on pump model.
Weight with packaging	approx. 0.4 kg more than without packaging
Connections to pipe network	
Heating circuit side connections	G 1 male thread, with flat seals
Boiler side connections	G 1 male thread, with flat seals
Tightening torques for screw fittings	
G ¾	35 Nm
G 1	55 Nm
Materials	
Fittings	Brass CW617N
Pipes	Stainless steel Ø33 mm
Bypass pipe	Brass CW617N
Gravity brake	POM, NBR, stainless steel
Wall brackets	Galvanised sheet steel
Retaining bracket	Spring steel
Insulation shell	EPP (expanded polypropylene)
O-rings	EPDM
Plastics	impact-resistant and temperature-resistant
Flat seals	AFM 34/2
Other	
Circulation pump	See separate pump documentation
Actuator including controller	see separate actuator documentation.

4 Pressure loss diagram

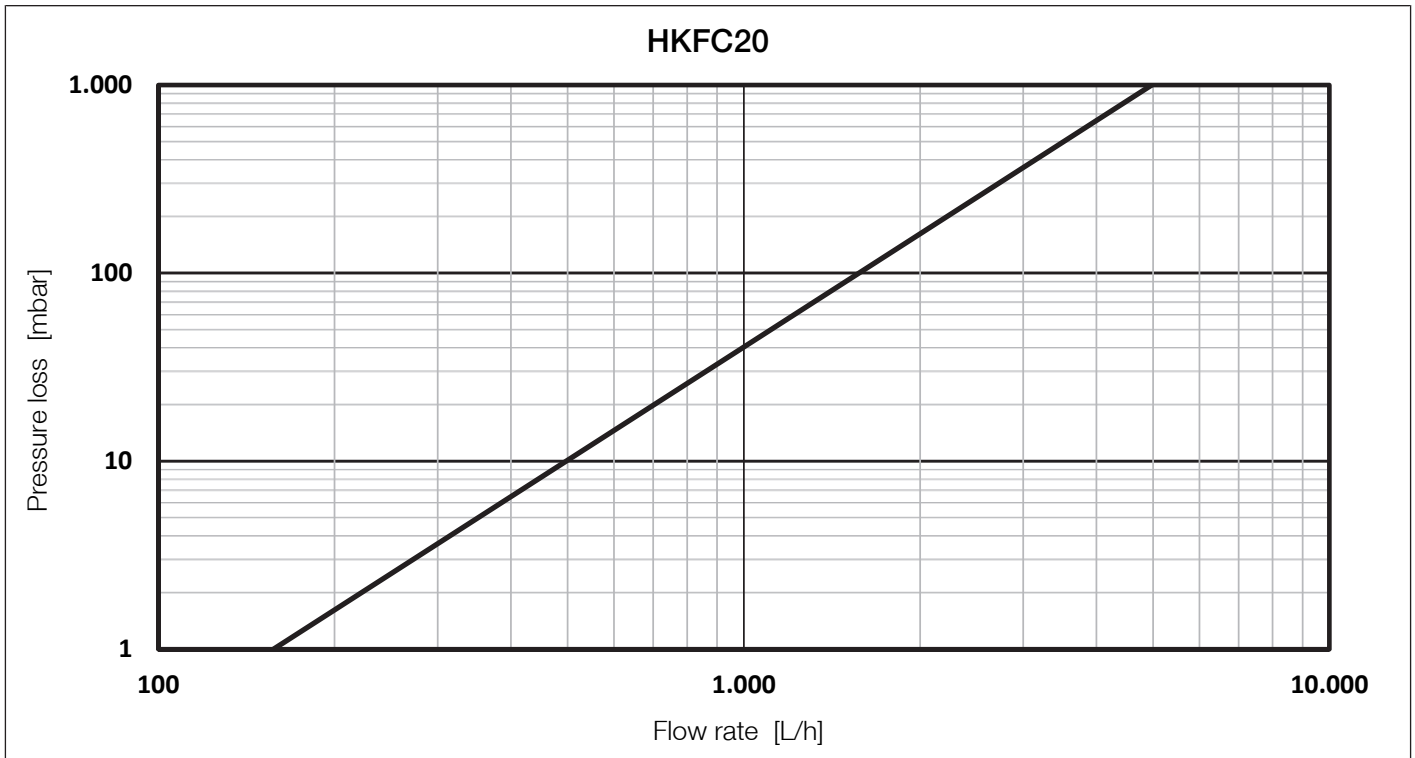

5 Dimensions

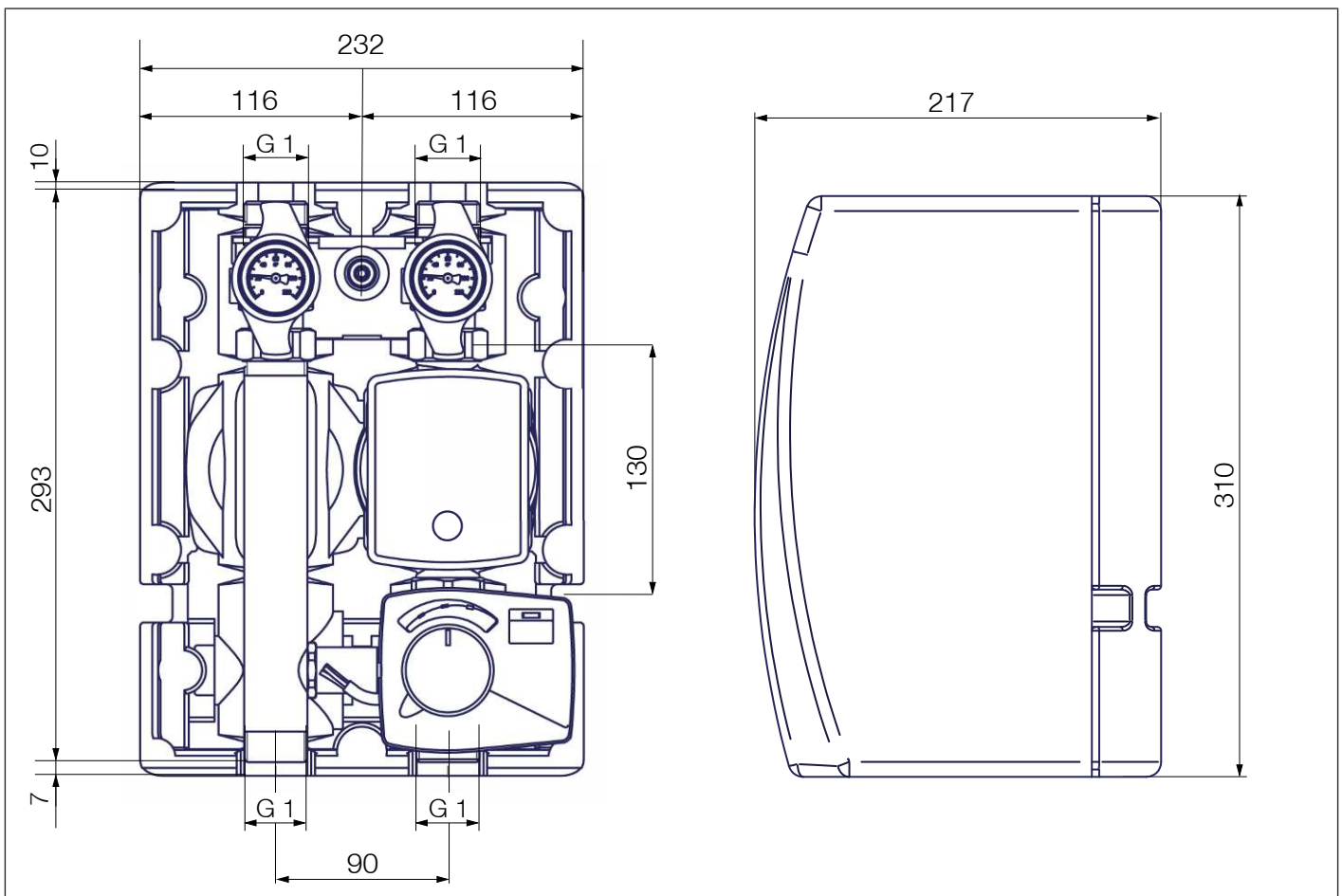

6 Component overview

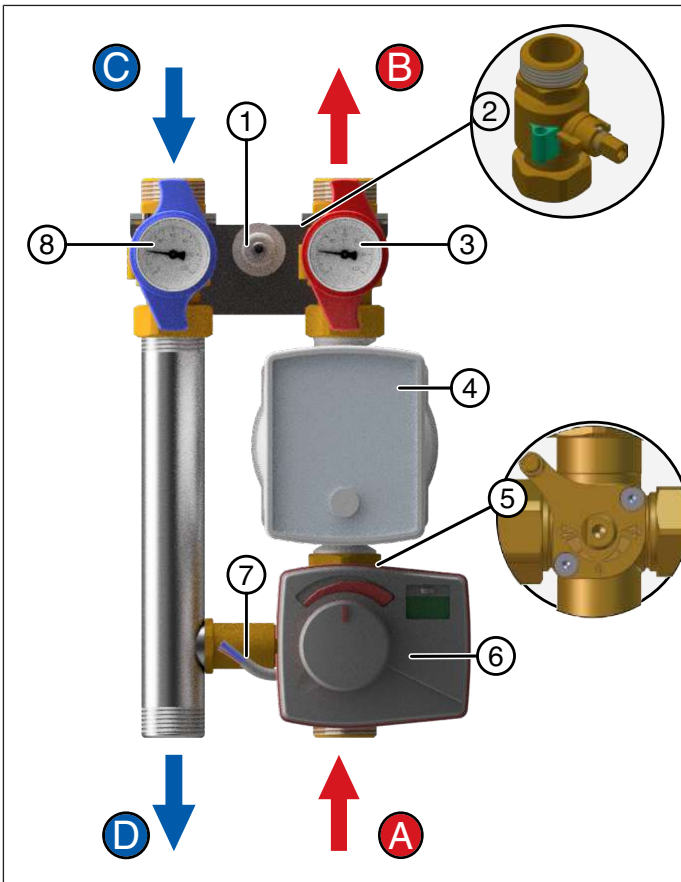

- | | |
|---|-------------------------------|
| A | Boiler circuit supply inlet |
| B | Heating circuit supply outlet |
| C | Heating circuit return inlet |
| D | Heating circuit supply outlet |

- | | |
|---|--|
| 1 | Wall bracket |
| 2 | Thermowell for supply line temperature sensor (optional) |
| 3 | Ball valve with gravity brake (supply) |
| 4 | Circulation pump |
| 5 | 3-way mixing valve |
| 6 | Actuator including controller |
| 7 | Bypass pipe |
| 8 | Ball valve (return) |

7 Installation and commissioning

7.1 General safety information

DANGER

Electrical energy!

Risk of death from electric shock.

- Work on parts carrying live voltage must only be carried out by trained electricians.
- Disconnect the power supply of the system and secure it against being switched back on before carrying out any installation, maintenance, cleaning or repair work.

NOTICE

Material damage!

Opening shut-off valves quickly produces pressure surges.

- Always open shut-off valves slowly and in a controlled manner.

NOTICE

Material damage!

Incorrect repair and replacement of individual components.

- When carrying out repairs and replacing parts, note the prescribed mounting positions and flow directions for the individual components which are being replaced.

7.2 Installation diagram

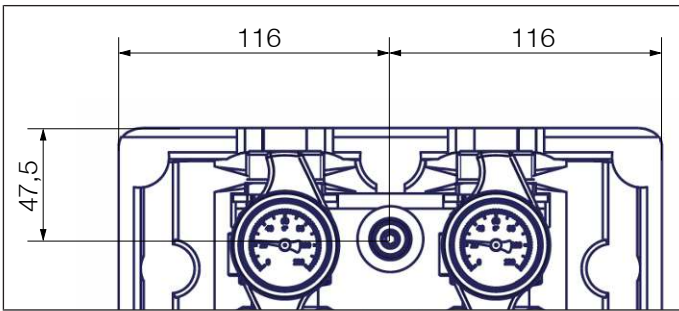

7.3 Installation

Before installing the unit and starting it for the first time, check all screw fittings and retighten if necessary!

Tightening torques for screw fittings

- Pump G 1, AFM 34/2 seals: 55 Nm
- Bypass G ¾, AFM 34/2 seals: 35 Nm

1. Remove the pump group front shell.

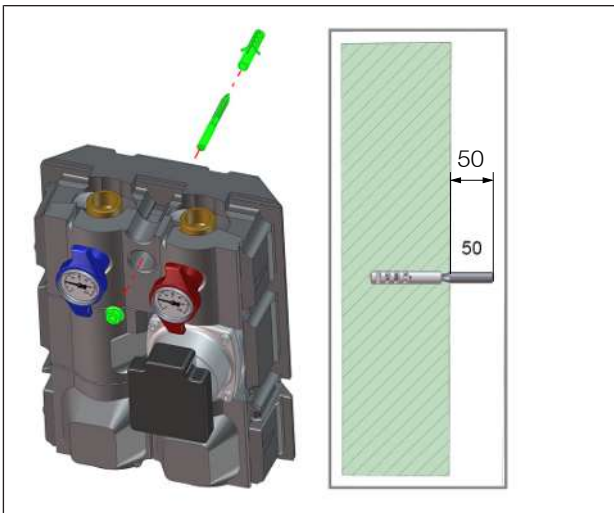

2. Drill the hole according to the screw and wall plug size.
3. Insert wall plug.
4. Screw the hanger bolt into the wall plug leaving at least 50 mm of the hanger bolt protruding from the wall.
5. Locate the pump group vertically on the wall (see installation diagram).
6. Fix the pump group using the nut on the hanger bolt.
7. Remove the thermometer handles and the intermediate insulation.
8. Connect the supply and return lines and check all screw connections are tight.

7.4 Starting the unit

- ✓ The pump group is fully installed.
- ✓ The fittings are preassembled at the factory; however, the tightness of the seal is to be checked before commissioning (pressure test).
- ✓ The pump group must be disconnected from the power supply and secured.
 1. Vent the heating system.
 2. Connect the power supply
 - ⇒ The pump group automatically switches itself on when the power supply is connected.
 3. Fit the intermediate insulation and thermometer handles.
 4. Fit the pump group front shell.

7.5 Controller and actuator adjustment

The setpoint temperature is preset to 50°C.

For further information on the controller and actuator please refer to the enclosed instructions.

7.6 Thermometer settings

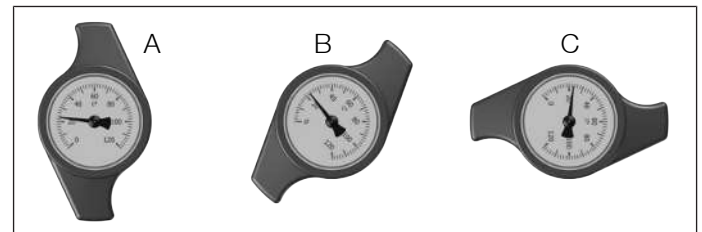

- | | |
|---|--|
| A | Operating position: gravity brake ready to work; ball valve open |
| B | Drain: gravity brake open; ball valve half open (only included in the supply line) |
| C | Service position: ball valve closed |

7.7 Switching the supply and return lines

✓ **The supply is on the right-hand side**

1. Disconnect the power supply and secure against reconnection.
2. Remove the actuator from the 3-way mixing valve.
3. Remove the retaining brackets and thermometer handles.
4. Remove the lines from the wall bracket and loosen the bypass pipe on the 3-way mixing valve.
5. Change the lines over.

⇒ **The supply is now on the left-hand side.**

6. Loosen the connection to the ball valve, rotate the return line and then tighten the connection to the ball valve again.
7. Remove the end cap from the 3-way mixing valve and then use it to close off the opposite side.
8. Connect the bypass pipe to the 3-way mixing valve and fit the lines into the wall bracket.
9. Reset the valve spindle and fit the actuator. Follow the separate operating instructions for the actuator.
10. Tighten all screw fittings and other connectors.
11. Check the seals on the pump group are not leaking.

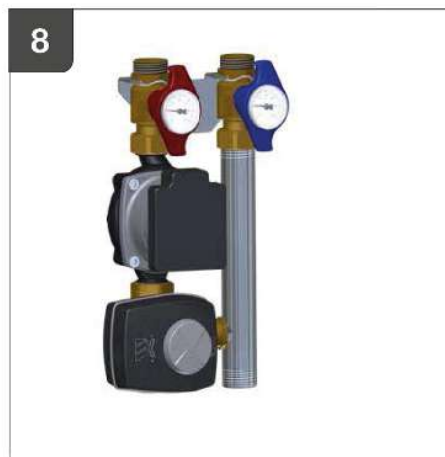
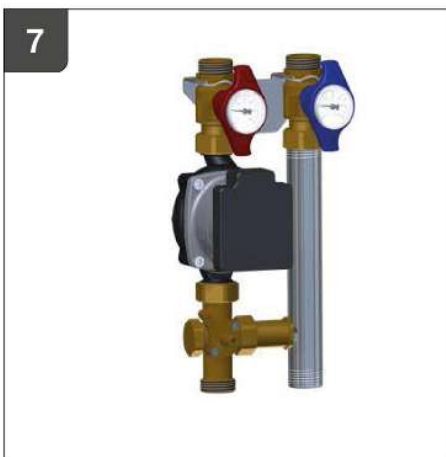
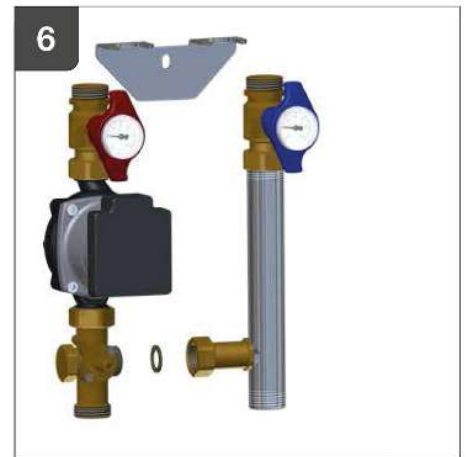
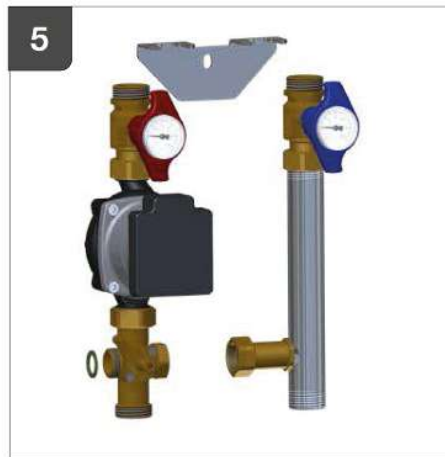
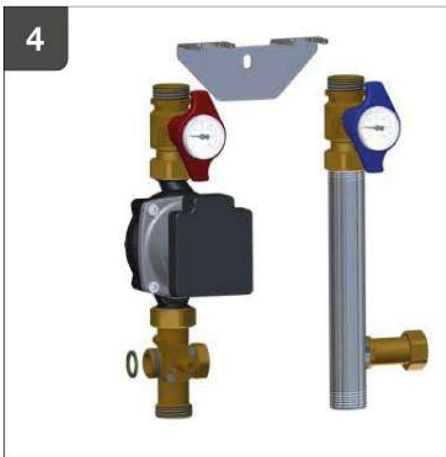
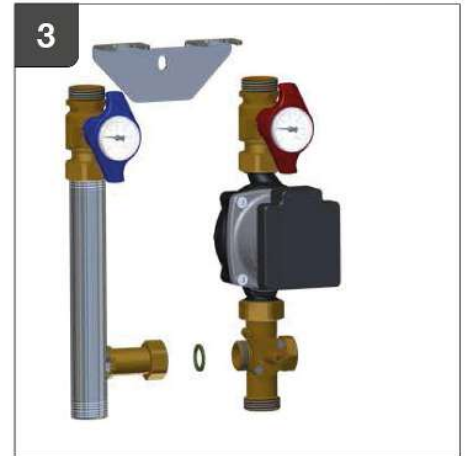
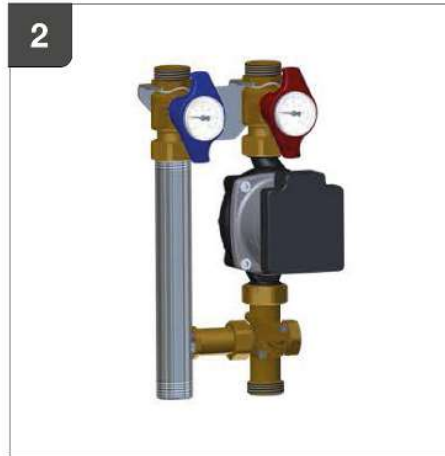
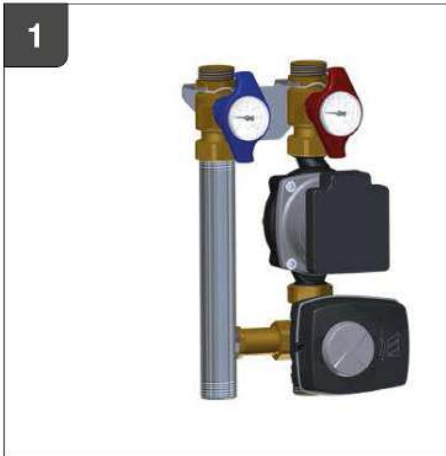

8 Maintenance

8.1 General safety information

DANGER

Electricity!

Risk of death from electric shock!

- Maintenance on the product (HKFC20) may only be carried out once the power supply has been disconnected.

WARNING

Hot surfaces!

Risk of serious burns.

- Do not touch the pipes or components during operation.
- Ensure that the product (HKFC20) has cooled down before carrying out maintenance, cleaning and repair work.
- Wear heat-resistant safety gloves if it is necessary to carry out work on hot components.

8.2 Annual maintenance schedule

General visual inspection

- Check the product for leaks and, where necessary, retighten connections with flat seals or replace the seals.

Functional check

- Check the correct adjustment and operating and performance parameters.
- Check with the user in the event of anomalies.

Ball valves

- Check for correct operation of shut-off valves and ball valves.

Pump

- Be aware of noise build-up in the pump.

3-way mixing valve

- Check functionality of the 3-way mixing valve.

Actuator

- Check functionality of actuator.

Post-maintenance checks

- Check all loosened screw connections for a firm seating and retighten if necessary.
- Remove all tools, materials and other equipment used from the work area.
- Fill and vent the system.

8.3 Replacing wear parts

Note that the product has parts which are subject to wear that naturally occurs as a result of normal use, even when properly maintained and serviced.

Specifically, these are mechanical parts and parts which are in contact with hot water and steam such as hoses, seals, valves, etc.

Normal wear and tear is not a defect and is not covered under warranty or guarantee. Nevertheless, defects and malfunctions may only ever be remedied by trained specialist personnel.

Contact your specialist dealer for more information.

8.4 Removing the circulation pump

1. Disconnect the power supply and secure against reconnection.
2. Remove the pump group front shell.
3. Close the shut-off valves.
4. Remove the thermometer handles and the intermediate insulation.
5. Disconnect the circulation pump wiring.

WARNING

Hot water!

Severe scalding possible.

- Allow the product (HKFC20) to cool before carrying out any maintenance, cleaning or work repair.
 - Do not put hands into hot water when draining the product (HKFC20).
6. Undo the union nuts (X) and remove the circulation pump.

8.5 Installing the circulation pump

1. Replace the seals on the screw connections.
2. Position the circulation pump and tighten the union nuts (X) (G 1 55 Nm).
3. Connect the circulation pump wiring.
4. Slowly open the ball valve by turning the thermometer handle.
5. Slowly pressurise the pump group and bleed the system if necessary.
6. Check the seals on the pump group are not leaking.
7. Reconnect the power supply to the pump group.
8. Remove the thermometer handles.
9. Fit the intermediate insulation.
10. Fit the thermometer handles.
11. Fit the front shell.

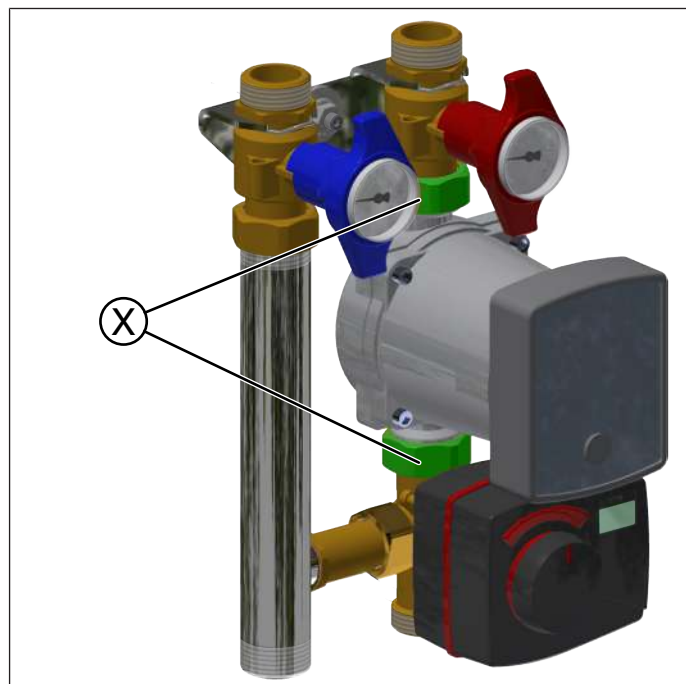

8.6 Fitting the 3-way mixing valve

1. Replace the seals on the screw connections.
2. Position the 3-way mixing valve (A) and tighten the union nuts (X).
- Pump G 1, AFM 34/2 seals: 55 Nm.
- Bypass G ¾, AFM 34/2 seals: 35 Nm.
3. Fit the actuator (B).
4. Slowly open the ball valve by turning the thermometer handle.
5. Reconnect the power supply to the pump group.
6. Remove the thermometer handles.
7. Fit the intermediate insulation.
8. Fit the thermometer handles.
9. Fit the front shell.

Instructions for fitting/removing the actuator can be found in the relevant manufacturer's manual.

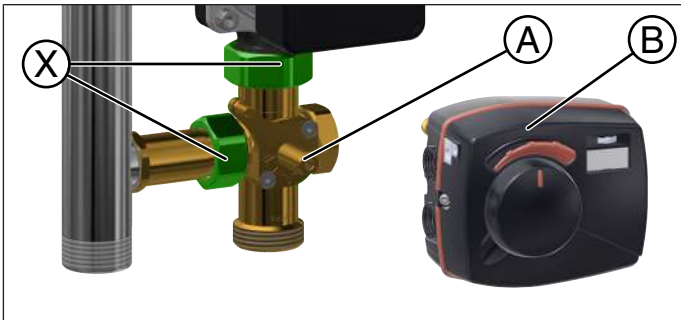

8.7 Fitting the actuator

Depending on the position of the supply and mixing valve, a distinction is made between a left-handed installation (mixing valve on the left) or a right-handed installation (mixing valve on the right).

1. Disconnect the pump group from the power supply.
2. Apply the sticker with the scale as shown in the images below.
3. Rotate the arrow on the knob on the actuator to 12 o'clock.
4. Adjust the wiring on the actuator when exchanging the supply and return line. Note direction of rotation.
5. Align the valve spindle to 45° as shown in the images below.
6. For a left-handed installation, fit the actuator upside down.
7. Carefully place the actuator onto the spindle. Make sure it is securely located.
8. Reconnect the power supply to the pump group.
9. Check the functionality of the actuator.

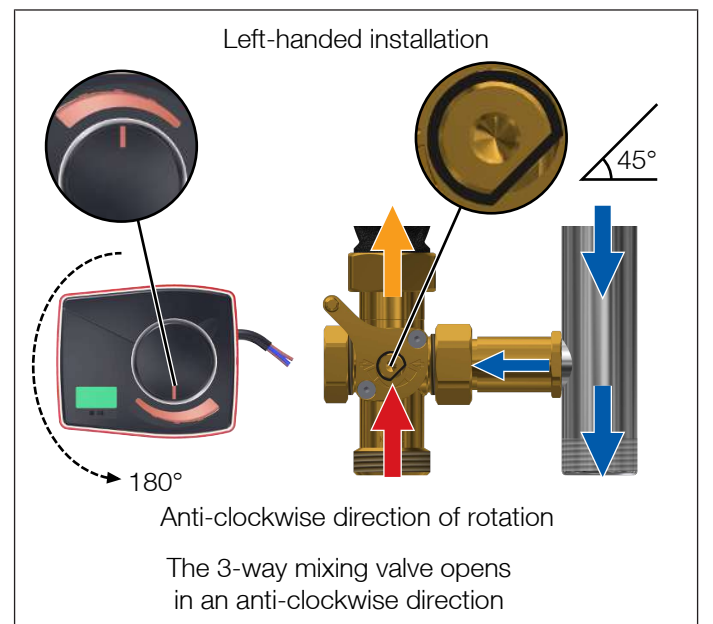
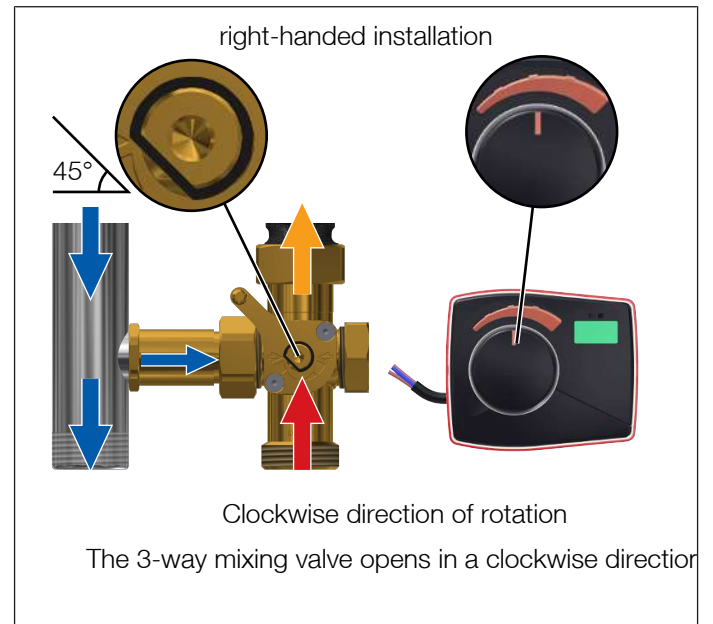

9 Disposal

WARNING

Potential for contamination of the environment and groundwater from improper disposal!

- The legal regulations and guidelines in the country of operation must be observed when disposing of components and operating materials.
1. Disassemble the product (HKFC20) properly or commission a specialist company to do so.
 2. Sort the assemblies and component parts into recyclable materials, hazardous substances and operating materials.
 3. Dispose of the assemblies and components in accordance with local laws and regulations or take them to be recycled.

9.1 Notification of administrative bodies and the manufacturer

Inform the manufacturer of decommissioning and disposal of the product (HKFC20) for statistical purposes.

9.2 Return to the manufacturer

Get in contact with the manufacturer if you would like to return the product (Pump group HKFC20) or parts of it.

10 Warranty

WATTS products are tested extensively. WATTS therefore guarantees only the replacement or, at the sole discretion of WATTS, the free-of-charge repair of components of the supplied products where these, in the opinion of WATTS, exhibit verifiable manufacturing faults. Warranty claims due to defects or defects of title may be asserted within one (1) year of delivery/transfer of risk. Excluded from the warranty are damages attributable to normal use of the product or friction and damages resulting from modifications or non-authorized repairs on the products, for which WATTS rejects all claims for compensation (direct or indirect). (For more detailed information, please refer to our website.) In all cases, supply is subject to the General Terms and Conditions, which can be found at www.watts.eu/en/gtc.

